

Get Your Refrigeration Working for You, Not Against You

Consider a Rack System that Uses Energy Efficiently and Provides Hot Water and Space Heating

Starting in the machine room, the schematic shows multiple parallel compressors of various sizes used in staged operation. A suction manifold takes the vapor heat captured from the retail cases and walk-ins and feeds it to a discharge manifold which then feeds it to three-way heat reclaim valves linked to the store's water heater and to its HVAC heat reclaim coil in the store's supply ductwork. Any excess heat that is not needed by either of these two loads is then exhausted through a rooftop or ground mounted outdoor condenser.

The outdoor condenser pulls outside air through it, fully condensing the refrigerant. From there the condensed liquid is piped to the liquid manifold where refrigerant is distributed to the retail cases. There, heat is removed from the cases and delivered to the suction manifold as warmed vapor, thus completing the cycle.

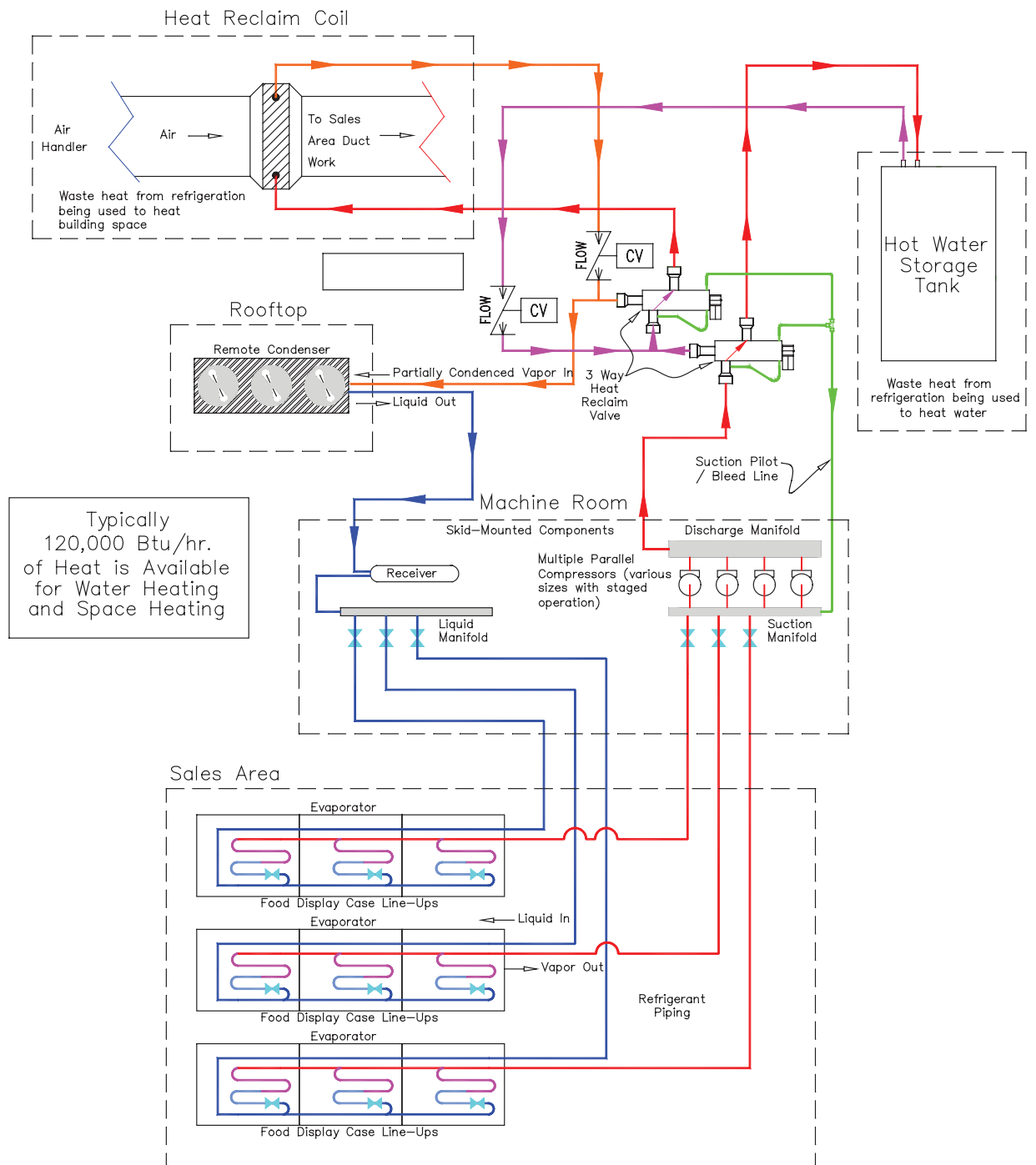

www.maced.org

Line art by MACED Energy Specialist, Joshua Bills, with consultation from Richard Jankowski of General Refrigeration, Inc.